



功得電子工業股份有限公司
CONQUER ELECTRONICS CO.,LTD.

規格書

Spec. No. **SFA-900**

Specification For Approval

產品名稱：MMS-P 系列
高電流陶瓷微型保險絲

Product Name : MMS-P
High Current Ceramic Micro Fuse

www.conquer.com.tw

五股廠：新北市五股區五權五路26號(新北產業園區)
Wugu Factory: No.26, Wucyuan 5th Rd., Wugu Dist.,
(New Taipei Industrial Park) New Taipei City
24888, Taiwan
TEL: +886-2-89902189(Rep.)
FAX: +886-2-8990-2577

北投廠：台北市北投區立德路120巷15號
Peitou Factory: No. 15, Lite Road, Peitou,
Taipei 11259, Taiwan.
TEL: +886-2-2895-8895(代表號)
FAX: +886-2-2895-8880



History of Change

REV.	Description	Date	Drawn	Designed	Checked	Approved
1	新制定文件	2015.07.06	陳佳鈺	翁靜好	葉志強	蕭煥益
2	1. 修改項目2、3字碼標示 2. 修改項目2建議銅箔尺寸	2016.07.11	陳佳鈺	翁靜好	葉志強	蕭煥益
3	1. 修改規格書封面格式 2. 新增規格：20A、30A、40A	2017.03.16	陳佳鈺	翁靜好	葉志強	蕭煥益

Conquer Electronics Co., LTD.

No.26, Wucyuan 5th Rd., Wugu Dist.,(New Taipei Industrial Park) New Taipei City 24888, Taiwan TEL:+886-2-8990-2189 (代表號) FAX:+886-2-8990-2577

Peitou Factory : No. 15, Lane 120, Lite Road, Peitou, 11248, Taipei, Taiwan. TEL: +886-2-2895-8895 (代表號) FAX:+886-2-2895-8880

E-mail: conqfuse@ms62.hinet.net Official Website: <http://www.conquer.com.tw>

1 適用範圍

- 1.1 電動工具 Power Tool 【Lithium Battery,Rechargeable】
- 1.2 電動機車 Electric Assistant Bicycle

2 形狀及尺寸如下圖 單位: mm

Shape & Size as following illustrations.

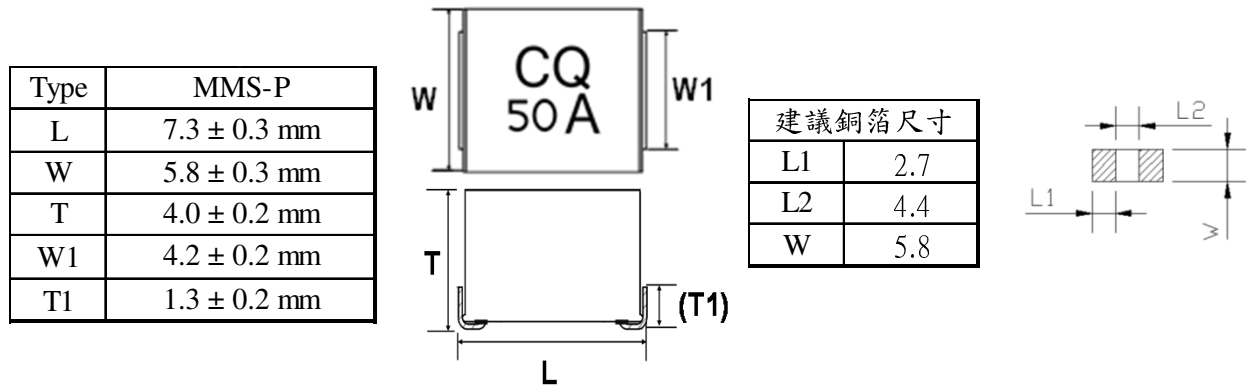

- 2.1 構造形狀 Structure & Shape : 如上圖 As shown in figure above
- 2.2 額定電壓 Rated Voltage: 35V & 60V
- 2.3 額定電流 Rated Current: 20A~50A

3 材料 Material :

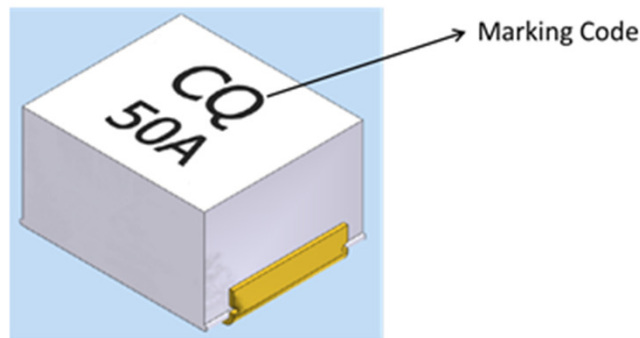

Portion Name	Material
Cover	Ceramic
Element	Copper & Tin
Bottom	Ceramic
Package	Silicone
Marking	UV INK

Conquer Electronics Co., LTD.

No.26, Wucyuan 5th Rd., Wugu Dist.,(New Taipei Industrial Park) New Taipei City 24888, Taiwan TEL:+886-2-8990-2189 (代表號) FAX:+886-2-8990-2577

Peitou Factory : No. 15, Lane 120, Lite Road, Peitou, 11248, Taipei, Taiwan. TEL: +886-2-2895-8895 (代表號) FAX:+886-2-2895-8880

E-mail: conqfuse@ms62.hinet.net Official Website: <http://www.conquer.com.tw>



4 電氣特性 Electrical Characteristics :

4.1 負載容量: 通過額定電流值 100 % (亦即 $1.0 \times I_n A$)4小時以上，能繼續通電無任何熔化現象。

Loading Capacity : Through the 100 % rating current ($1.0 \times I_n A$) loading, and keep current continuously without any melting. (Can keep 4 hours minimum)

4.2 溫度特性: 通過額定電流值100%(亦即 $1.0 \times I_n A$)1.5小時，繼續維持原加之電流，每隔十分鐘測試一次，連續測三次，溫度不得升高，若使用熱偶式測量方法。(Thermocouple method) 則本體溫升在 $200^{\circ}C$ 以下。

Temperature: Loading the 100 % ($1.0 \times I_n A$) for 1.5 hours, keep testing it with the original current every 10 minutes. Continue to test it for 3 times. The temperature is not allowed to be higher. The main temperature rise is below $200^{\circ}C$ by way of Thermocouple Method.

4.3 過載熔斷: 請參照下表。Melting due to overloading: Details as follows Table.

※最大熔斷時限Operating Characteristics

安培數	100% Rating		250% Rating	
	Min.	Max.	Min.	Max.
20A~50A	4 hr			60 sec

5 突波實驗：為適應電感或電容性電路所產之暫態電流，本品可承受最少1ms 10 I_n 電流之突波。

Pulse Test: In order to stand transient current caused by inductive or capacitive, the fuses are designed to have minimum clearing time of 1 millisecond at 1000% rated current.

6 遮斷能力 Interrupting rating :

20A~50A : 300 amperes at 35V DC
300 amperes at 60V DC

7 **包裝** : 1000 pcs (13'') in an inner box. 內盒印明下列標示:料號、額定(電壓、電流、遮斷能力)及安規名稱。包裝材料均符合RoHS或者HF的環保要求,且包裝材料不會和零件發生化學反應,造成不良。

Packing : 1000 pcs (13'') in an inner box. The following items indicated on the box.

Mark: Catalog number; ratings (voltage, current, interrupting capacity), and safety mark.

The packing material conforms to ROHS or the HF environmental protection request. And the packing material can't have the chemical reaction with the components.

7.1 Carrier Tape

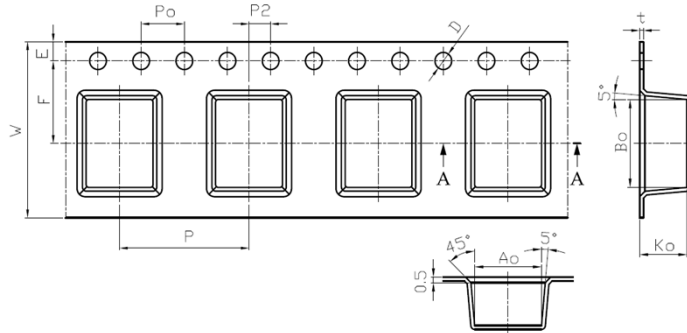

Item	W	P	E	F	P2	D	P ₀	10P ₀	A ₀	B ₀	K ₀	t
Criterion	16.00	12.00	1.75	7.50	2.00	1.50	4.00	40.00	6.20	8.00	4.40	0.35
Tolerance	0.30	0.10	0.10	0.10	0.10	0.10	0.10	0.20	0.10	0.10	0.10	0.05
	-0.30	-0.10	-0.10	-0.10	-0.10	0.00	-0.10	-0.20	-0.10	-0.10	-0.10	-0.05

7.1 Reel

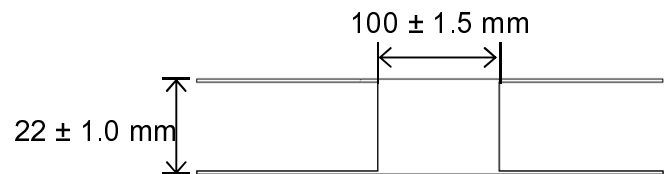
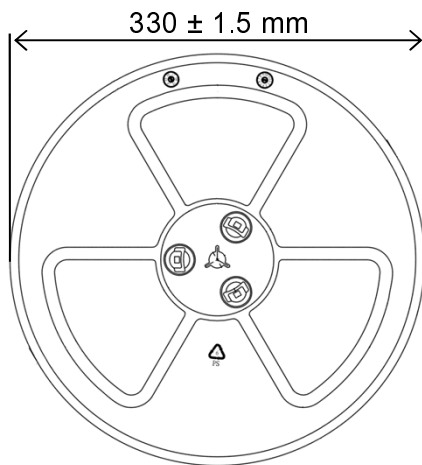

8 **其他** Other :

8.1 除非另有指定,上述機械、電器特性,係於常溫,標準狀況下測試之。

Unless otherwise, specified, all tests to be performed at 25±5°C and 35-75% RH.

8.2 於標準狀況下儲放一年,本品能確保上述機械與電氣之特性。

After one year's storage under normal condition, this item is guaranteed to meet the requirements mentioned above.



9 標記/安規認證 Mark/ Safety certification :

9.1 標記 Mark

貼紙 Label

FUSE 7.3 X 5.8 mm	Q.C PASS:		
TYPE:MMS-P			Q'TY:
SHORT DESCRIPTION	A	V DC	DATE: 20140402
High Current Ceramic Micro Fuse			Breaking Capacity
UL 248-14	MMS*****		IR:300A 35V DC IR:300A 60V DC



Mark Approvals	c us	Nominal Resistance	Nominal Melting I ² t
		Cold Ohms	A ² Sec
20 A	*	0.0014 - 0.0026	108.000
30 A	*	0.0008 - 0.0016	270.000
40 A	*	0.0007 - 0.0013	416.000
50 A	*	0.0005 - 0.0009	1750.00

* : Have safety certify

Note: 1. Measured at ≤ 10% of rated current and 25°C ambient
2. Melting I²t at 1000% of current rating

9.2 安規認證：UL 認證號碼 E82636。

Safety certification：UL File No. E82636

10 產品名稱 Product Name :

品名	安培數
MMS-P ___A ___V	20A~50A

例：
1 2 3

- 1 系列品名 Series Model : MMS-P
- 2 安培數 Ampere Rating : 20A~50A
- 3 伏特數 Voltage : 35V / 60V

Conquer Electronics Co., LTD.

No.26, Wucyuan 5th Rd., Wugu Dist.,(New Taipei Industrial Park) New Taipei City 24888, Taiwan TEL:+886-2-8990-2189 (代表號) FAX:+886-2-8990-2577

Peitou Factory : No. 15, Lane 120, Lite Road, Peitou, 11248, Taipei, Taiwan. TEL: +886-2-2895-8895 (代表號) FAX:+886-2-2895-8880

E-mail: conqfuse@ms62.hinet.net Official Website: http://www.conquer.com.tw



11 IT曲線圖 Clear Time Curve(I vs t curve) :

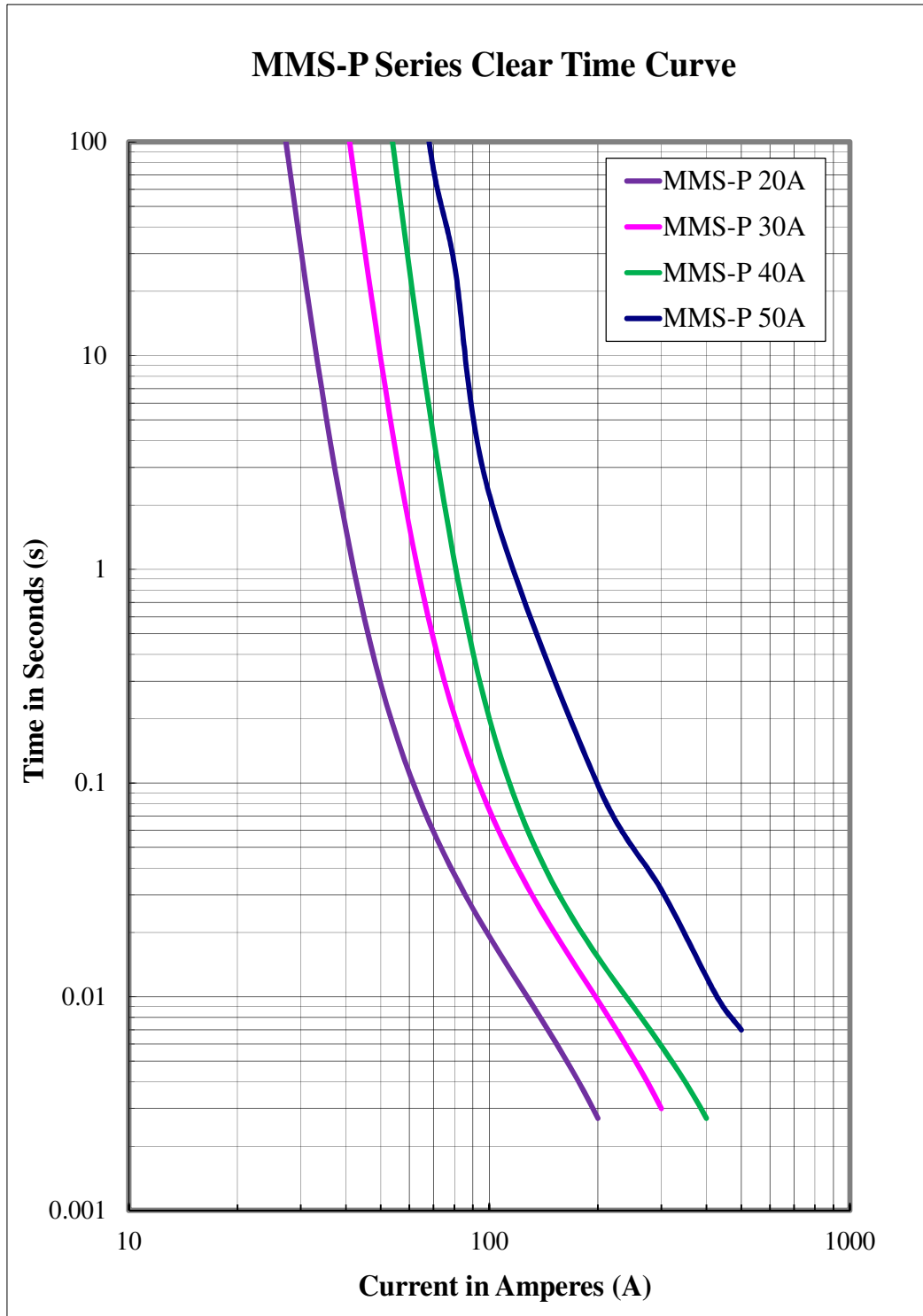

Conquer Electronics Co., LTD.

No.26, Wucyuan 5th Rd., Wugu Dist.,(New Taipei Industrial Park) New Taipei City 24888, Taiwan TEL:+886-2-8990-2189 (代表號) FAX:+886-2-8990-2577

Peitou Factory : No. 15, Lane 120, Lite Road, Peitou, 11248, Taipei, Taiwan. TEL: +886-2-2895-8895 (代表號) FAX:+886-2-2895-8880

E-mail: conqfuse@ms62.hinet.net Official Website: <http://www.conquer.com.tw>



12 I²T曲線圖 Standing Pulse(I²t vs t curve) :

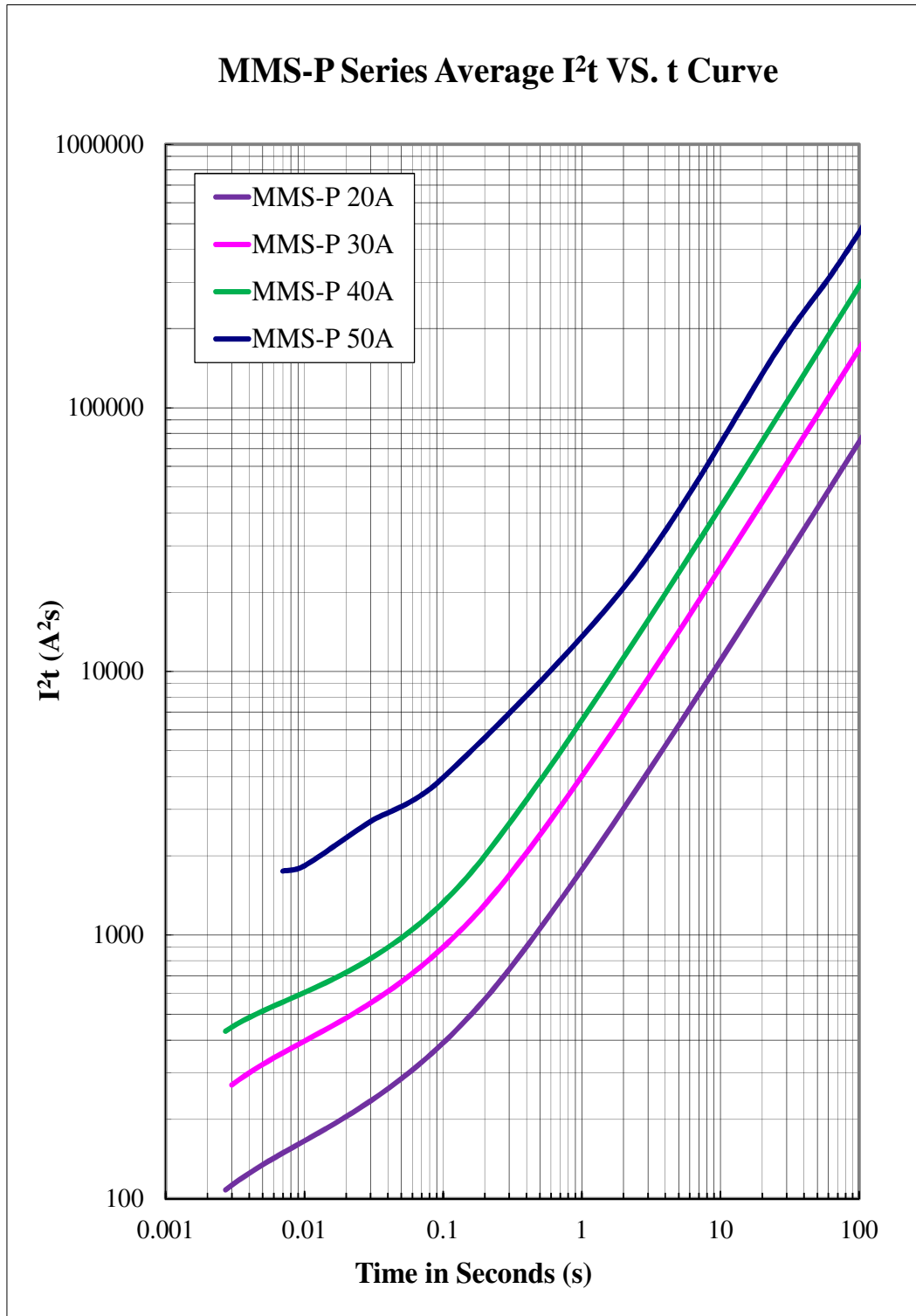

Conquer Electronics Co., LTD.

No.26, Wucyuan 5th Rd., Wugu Dist.,(New Taipei Industrial Park) New Taipei City 24888, Taiwan TEL:+886-2-8990-2189 (代表號) FAX:+886-2-8990-2577

Peitou Factory : No. 15, Lane 120, Lite Road, Peitou, 11248, Taipei, Taiwan. TEL: +886-2-2895-8895 (代表號) FAX:+886-2-2895-8880

E-mail: conqfuse@ms62.hinet.net Official Website: <http://www.conquer.com.tw>

13 焊接方法 Soldering Method :

- 13.1 手焊 Hand soldering : 350°C, 3 Sec. max
- 13.2 波焊 Wave soldering : 260°C, 10 Sec. max
- 13.3 迴焊 Reflow soldering : 260°C, 30 Sec. max

14 迴焊建議曲線圖 Recommended Reflow Soldering Curve :

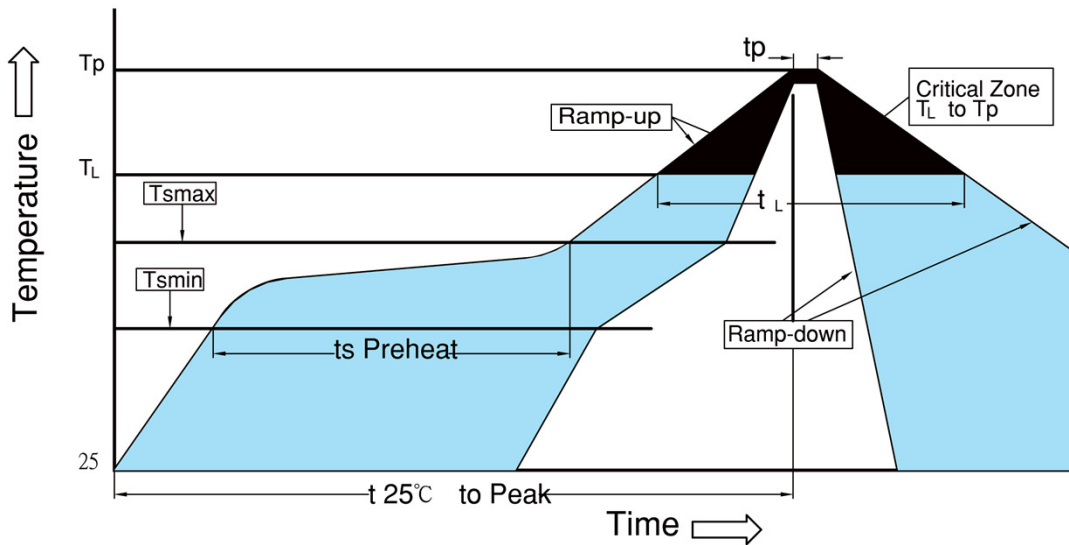

Reflow Condition		Pb-free assembly
Pre Heat	Temperature Min (T_s (min))	150°C
	Temperature Max (T_s (max))	200°C
	Time (Min to Max) (t_s)	60-180 seconds
Average Ramp-up Rate (Liquidus Temp (T_L) to peak)		3°C/second max
T_s (max) to T_L -Ramp-up Rate		5°C/second max
Reflow	Temperature (T_L) (Liquidus)	217°C
	Time (t_L)	60-150 second
Peak Temperature (T_P)		260 ^{+0/-5} °C
Time within 5°C of actual peak Temperature (t_p)		10 ~ 30 seconds
Ramp-down Rate		6°C/second max
Time 25°C to peak Temperature ($t_{25^\circ\text{C to peak}}$)		8 minutes max
Do not exceed		260°C



15 MMS-P 溫度曲線圖 Temperature Derating curve :

15.1 環境溫度對應電流承載能力，請參照下曲線圖。

Ambient temperature on current-carrying capacity.Details as follows curve.

15.2 工作溫度 Operating Temperature Range : -55°C ~ 125°C

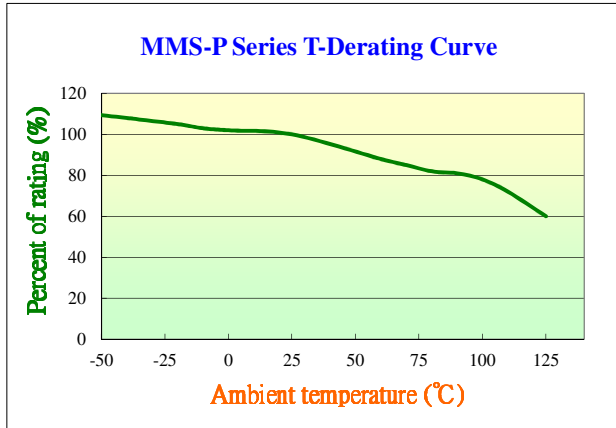

16 信賴性規範 Product Characteristics & Reliability Tests :

Test item	Test Description & Reference
Humidity unload test	MIL-STD-202G , Method 103B , Test Condition A Heat (40±0.5°C) & High Humidity (95±1% RH) , 240 hours , ΔR<15%
Thermal shock test	MIL-STD-202G, Method 107G , Test Condition B Temperature setup : 25°C ~ -65°C ~ 25°C ~ 125°C Time setup : -65°C (30min)~25°C (5min)~125°C (30min)~25°C (5min) · 5 cycles , ΔR<15%
Vibration test	MIL-STD-202G , Method 201A Frequency setup : 10 ~ 55 ~ 10 Hz Time setup : 1 Minute/cycle (X-Y-Z , 120 Cycles , 6hours) · ΔR<15%
Salt spray Test	MIL-STD-202G , Method 101E , Test Condition A Salt spray concentration : 5 ± 1% Test liquid temperature : 35 ± 0.5°C 96hours , ΔR<15
Solderability test	Reference IEC 68-2-58 Temperature setup : 235 ± 5°C , 2 ± 0.2 sec After test terminal electrode wetting area must be greater than 95%
Resistance to Soldering Heat Test	Reference IEC 68-2-58 Temperature setup : 260± 5°C , 10± 1 sec ΔR<15% Air does not leak from the case in the item of Solder ability.
Pushing Force Test	Pushing φ2.5 Pushing force : Min 5 kgf (49N)

Conquer Electronics Co., LTD.

No.26, Wucyuan 5th Rd., Wugu Dist.,(New Taipei Industrial Park) New Taipei City 24888, Taiwan TEL:+886-2-8990-2189 (代表號) FAX:+886-2-8990-2577

Peitou Factory : No. 15, Lane 120, Lite Road, Peitou, 11248, Taipei, Taiwan. TEL: +886-2-2895-8895 (代表號) FAX:+886-2-2895-8880

E-mail: conqfuse@ms62.hinet.net Official Website: http://www.conquer.com.tw