



功得電子工業股份有限公司
CONQUER ELECTRONICS CO.,LTD.

規格書

Spec. No. SFA091

Specification For Approval

品名： **MMT** 系列 慢速型保險絲

Type： **MMT** *Time Lag Radial Lead Micro Fuse Series*

www.conquer.com.tw

五股廠：新北市五股區五權五路26號(新北產業園區)
Wugu Factory:No.26, Wucyuan 5th Rd., Wugu Dist.,
(New Taipei Industrial Park) New Taipei City
24888, Taiwan
TEL:+886-2-89902189(Rep.)
+886-2-2CONQUER(Rep.)
FAX:+886-2-8990-2577

北投廠：台北市北投區立德路120巷15號
Peitou Factory:No. 15, Lite Road, Peitou,
Taipei11259, Taiwan.
TEL:+886-2-2895-8895(代表號)
FAX:+886-2-2895-8880



History of Change

REV.	Description	Date	Drawn	Designed	Checked	Approved
1	新增規格書	2014.08.07	勤彥鳴	邱俊傑	蔡進義	蔡其湖
2	1. 額定電流Rated Current 原為40mA~10A修正為50mA~10A 2. 增加壓降 3. 加入Temperature Derating curve	2015.02.12	勤彥鳴	邱俊傑	蔡進義	蔡其湖

Conquer Electronics Co., LTD.

No.26, Wucyuan 5th Rd., Wugu Dist.,(New Taipei Industrial Park) New Taipei City 24888, Taiwan TEL:+886-2-8990-2189 (代表號) FAX:+886-2-8990-2577

Peitou Factory : No. 15, Lane 120, Lite Road, Peitou, 11259, Taipei, Taiwan. TEL: +886-2-2895-8895 (代表號) FAX:+886-2-2895-8880

E-mail: conqfuse@ms62.hinet.net Official Website: <http://www.conquer.com.tw>

~ 立式微小型保險絲 ~
Fuses for Instrument, Power and Telephone (Non-indicating)

- 1 **適用範圍**: 本標準適用於保護儀器、電源供應器和電話機用之立式微小型熔斷保險絲。
 Available Range: For protecting instruments, power supplies and telephone sets.
- 2 **形狀及尺寸如下圖** 單位: mm
 Shape & Size as following illustrations.

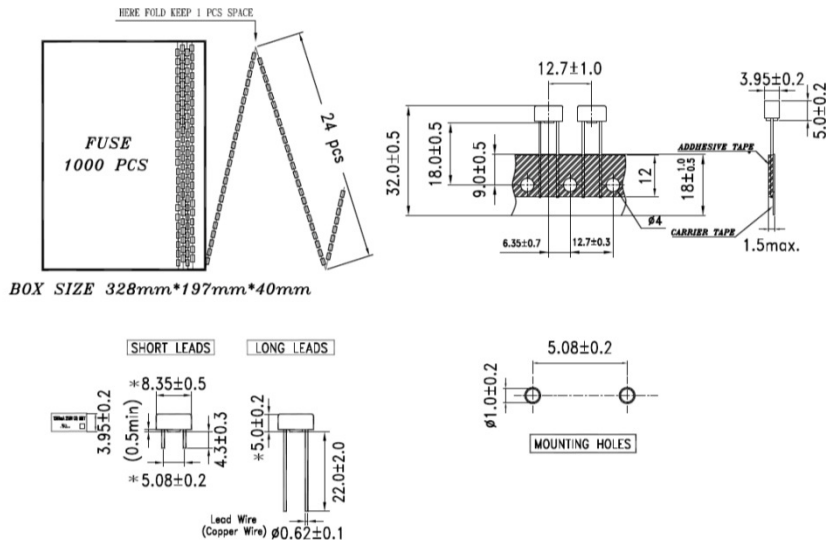

2.1 構造形狀 Structure & Shape : 如上圖 As shown in figure above

2.2 額定電壓 Rated Voltage: 250V AC

2.3 額定電流 Rated Current: 50mA~10A

2.4 上圖印字為示意安培數及安規標誌

Above figure marking is only an example for current rating and safety mark.

3 **材料 Material:**

3.1 上蓋: 不透明塑膠套蓋且不可破裂或變形。

Cap: Non-Transparent plastic Cap. No breaking or deformation is allowed.

3.2 下座: 不透明塑膠底座且不可破裂或變形。

Base: Non-Transparent plastic base. No breaking or deformation is allowed.

3.3 兩端端腳: 須以導電率良好之鍍錫銅為材料。

Two copper leads: Made of tin-plated copper wire for good conductivity.

NO.	Part Name 部品名稱	Volume 數量
A	Plastic Cap - Black 塑膠套蓋 - 黑色	1
B	Plastic base - Black 方形底座 - 黑色	1
C	Fuse Element 可熔體	1
D	Two copper leads 兩端端腳	2



4 **電氣特性** Electrical Characteristics:

- 4.1 負載容量: 通過額定電流值 150 % (亦即 $1.5 \times I_n A$) , 能繼續通電至少 1 小時無任何熔化現象。
Loading Capacity: Loading 150% Rated Current (i.e. $1.5 \times I_n A$) for flowing, and it's available to let current keep on flowing at least 1 hour without any melting. (Can keep 1 Hour minimum)
- 4.2 壓降測量: 以額定電流, 通過保險絲, 其兩端壓降值不得超過最大值, 可參考 IEC60127-3 Sheet 4。
Voltage drop: Loading 100% of rated current.(ie $1.0 \times I_n$), the voltage drops across the fuse-links shall not exceed the maximum values given on the relevant standard sheet (IEC 60127-3 sheet 4)
- 4.3 過載熔斷: 請參照下表。Melting due to overloading: Details as follows Table.

※最大熔斷時限 Operating Characteristics

安培數 Rating	150% Rating		210% Rating		275% Rating		400% Rating		1000% Rating	
	Min.	Max.	Min.	Max.	Min.	Max.	Min.	Max.	Min.	Max.
50mA~5A	60min	2min	400ms	10sec	150ms	3sec	20ms	150ms		
6.3A~10A	60min	2min	400ms	10sec	150ms	3sec	15ms	150ms		

5 **機械特性** Mechanical Properties:

- 5.1 拉力測試 Tensile Test : 上蓋與下座組合之拉力至少 3 kg。
For the tensile test, the force applied shall be 3 kg at least between cover and base.
- 5.2 推力測試 Thrust Test : 施力為 2 牛頓, 附腳不發生鬆動現象。
For the thrust test, the force applied shall be 2 N, the lead wire.
- 5.3 彎折強度 Bending Test : 附腳經過兩次反向之彎折後(彎折90度再折回原位謂之一次彎折) 不發生損壞。
No damage are to be visualized after two bends of opposite directions (bending through an angle of 90° and back is defined as one bend) of lead.

6 **突波實驗** Pulse Test:

為適應電感或電容性電路所產之暫態電流, 本品於10倍額定電流熔斷時間最少為 (※註1)
In order to stand transient current caused by inductive or capacitive, the fuses are designed to have minimum clearing time of (※Note1) millisecond at 1000% rated current.

※註1(Note1): 20ms (50mA~5A)
 15ms (6.3A~10A)

7 **耐久實驗** Endurance(On-Off Test):

- 7.1 於額定電流 ($1.0 \times I_n$) , 1 小時 ON , 15 分鐘 OFF , 共 100 次。
Loading 100% rated current ($1.0 \times I_n$), 1 hour ON, 15 minutes OFF. Keep 100 cycles.
- 7.2 接著以 1.5 倍之額定電流 ($1.5 \times I_n$) 通過 1 小時。
Followed by 1 Hour at 1.5 times the rated current ($1.5 \times I_n$).
- 7.3 再以 4-2 之方式量測壓降值, 所測得之壓降值不可比原值增加 10% 以上。
The voltage drop across the fuse-link after the test shall not have increased by more than 10% of the original value measured before the test



8 **高溫環境試驗** Derating Test:

本品置於70°C之高溫中，能以額定電流 (1.0 x In)通過1小時。

In an air circulating oven at 70°C, the fuses can load 100% rated current for 1 hour and they shall not operate.

9 **遮斷能力** Breaking Capacity(Interrupting rating):

35 amperes or 10 × rated current ; whichever is greater at 250V AC.

10 **包裝** 1000 PCS/盒 內盒印明下列標示:料號、額定(電壓、電流、遮斷能力)及安規名稱。

包裝材料均符合RoHS或者HF的環保要求,且包裝材料不會和零件發生化學反應，造成不良。

Packing : 1000 pcs in an inner box. The following items indicated on the box. Mark: Catalog number, ratings (voltage, current, interrupting capacity) and safety mark.

The packing material conforms to RoHS or the HF environmental protection request. And the packing material can't have the chemical reaction with the components.

11 **其他** Other:

11.1 除非另有指定，上述機械、電器特性，係於常溫，標準狀況下測試之。

Unless otherwise, specified, all tests to be performed at 25±5°C and 35-75% RH.

11.2 於標準狀況下儲放一年，本品乃確保上述機械與電氣之特性。

After one year's storage under normal condition, this item is guaranteed to meet the requirements mentioned above.

12 **標記/安規認證** Mark/ Safety certification:

						Voltage Drop (mv) MAX
50 mA	**		*	*	-	550
63 mA	**		*	*	-	480
80 mA	**		*	*	-	400
100 mA	**		*	*	-	350
125 mA	**		*	*	-	300
160 mA	**		*	*	-	280
200 mA	**		*	*	-	260
250 mA	**		*	*	-	240
315 mA	**		*	*	-	220
400 mA	**		*	*	-	200
500 mA	**		*	*	-	190
630 mA	**		*	*	-	180
800 mA	**		*	*	-	160
1 A	**	*	*	*	-	140
1.25 A	**	*	*	*	-	130
1.6 A	**	*	*	*	-	120

Conquer Electronics Co., LTD.

No.26, Wucyuan 5th Rd., Wugu Dist.,(New Taipei Industrial Park) New Taipei City 24888, Taiwan TEL:+886-2-8990-2189 (代表號) FAX:+886-2-8990-2577

Peitou Factory : No. 15, Lane 120, Lite Road, Peitou, 11259, Taipei, Taiwan. TEL: +886-2-2895-8895 (代表號) FAX:+886-2-2895-8880

E-mail: conqfuse@ms62.hinet.net Official Website: <http://www.conquer.com.tw>



						Voltage Drop (mv) MAX
2 A	**	*	*	*	-	100
2.5 A	**	*	*	*	-	100
3.15 A	**	*	*	*	-	100
4 A	**	*	-	-	-	100
5 A	**	*	-	-	-	100
6.3 A	**	*	-	-	-	100
8 A	**	*	-	-	-	100
10 A	**	*	-	-	-	100

*: 有安規認證 Have safety certify

** : 有安規認證及保險絲上蓋有安規印字標記 Have safety certify and safety mark on the cover

- : 安規申請中 In Process

13 系列品名列表 series model list :

品名 Type	安培數 Ampere Rating
MMT ___A ___V ___	50mA~10A

例: MMT A V
 1 2 3 4

1 系列品名 Series Model : MMT

2 安培數 Ampere Rating : 50mA~10A

3 伏特數 Voltage : 250V

4 包裝規範 Packaging Code :

包裝規範 Packaging Code	說明 Description
	1000 pcs:打帶(長腳) 1000 pcs on Taped(Long Lead)
(BK)	1000 pcs:散裝(短腳) 1000 pcs in Bulk(Short Lead)

Conquer Electronics Co., LTD.

No.26, Wucyuan 5th Rd., Wugu Dist.,(New Taipei Industrial Park) New Taipei City 24888, Taiwan TEL:+886-2-8990-2189 (代表號) FAX:+886-2-8990-2577

Peitou Factory : No. 15, Lane 120, Lite Road, Peitou, 11259, Taipei, Taiwan. TEL: +886-2-2895-8895 (代表號) FAX:+886-2-2895-8880

E-mail: conqfuse@ms62.hinet.net Official Website: <http://www.conquer.com.tw>



14 建議生產參數(無鉛焊錫使用)：

Recommended Process Parameters(for the action to Lead-free solder alloy)：

14.1 波峰參數 Wave Parameter	預熱溫度 Preheat temperature 最低溫度：100度 Temperature Minimum：100°C 最高溫度：150度 Temperature Maximum：150°C	錫槽溫度 Solder Pot Temperature 260度 Maximum 260°C Maximum 焊接時間 2~5 seconds Solder Dwell Time: 2~5 seconds
14.2 建議手持烙鐵焊接參數 Recommended Hand-Solder Parameters	烙鐵溫度：350°C +/- 5°C Solder Iron Temperature：350°C +/- 5°C 加熱時間：5 seconds max. Heating Time：5 seconds max.	

15 It曲線圖：

Time Current Characteristic Curve：

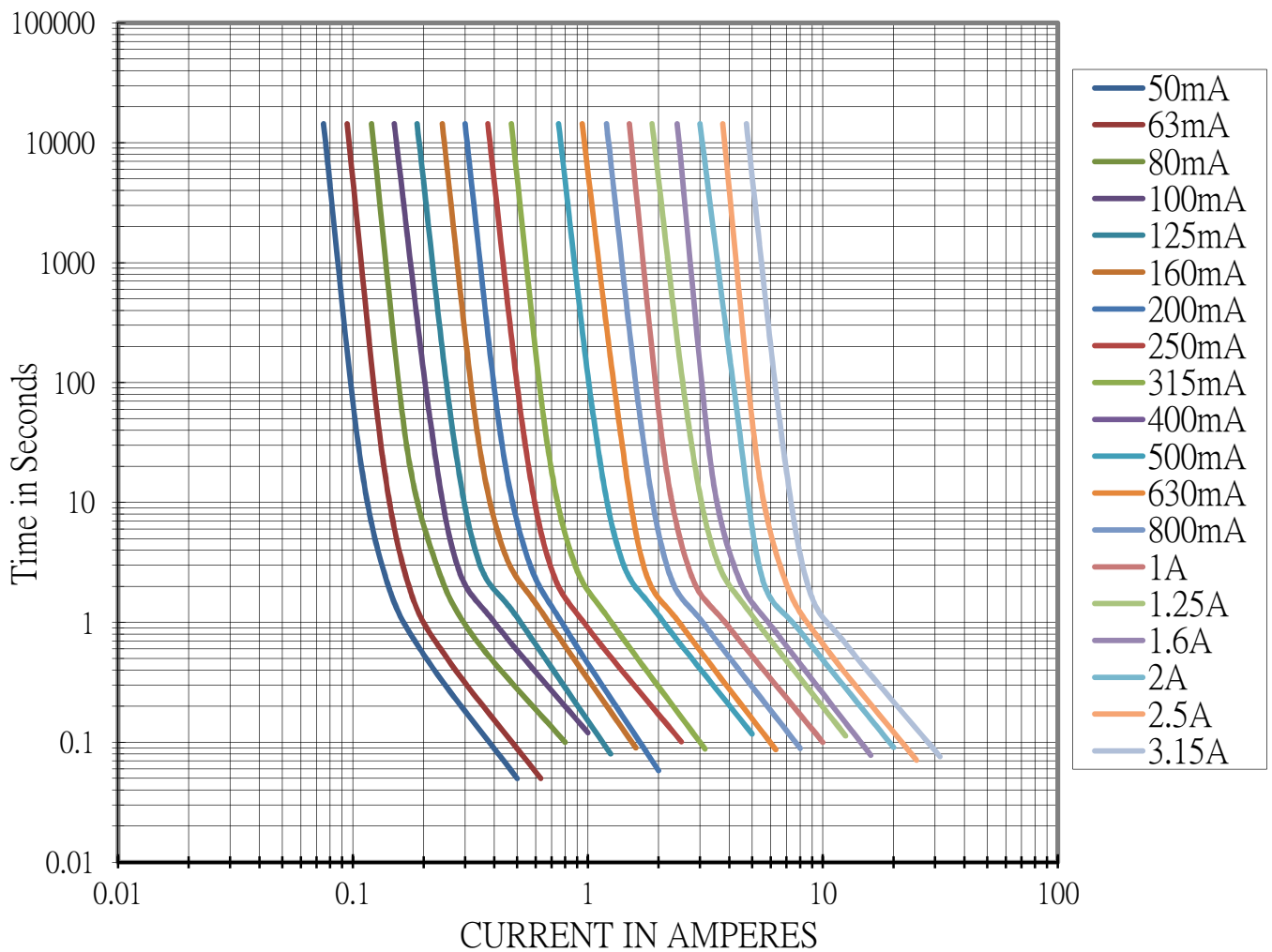

Conquer Electronics Co., LTD.

No.26, Wucyuan 5th Rd., Wugu Dist.,(New Taipei Industrial Park) New Taipei City 24888, Taiwan TEL:+886-2-8990-2189 (代表號) FAX:+886-2-8990-2577

Peitou Factory : No. 15, Lane 120, Lite Road, Peitou, 11259, Taipei, Taiwan. TEL: +886-2-2895-8895 (代表號) FAX:+886-2-2895-8880

E-mail: conqfuse@ms62.hinet.net Official Website: <http://www.conquer.com.tw>



16 I^2t 曲線圖 :

Average Melting I^2t Curves :

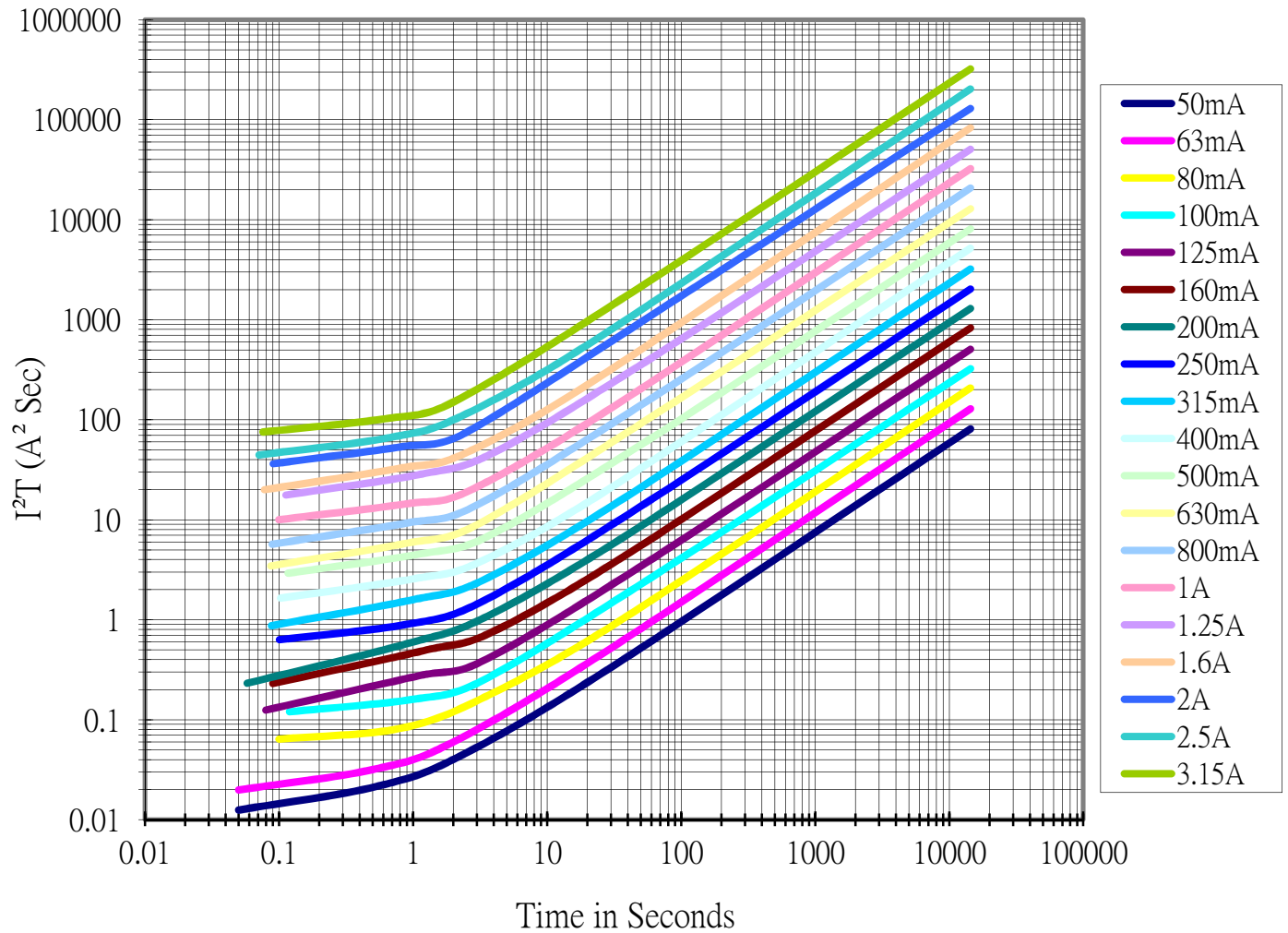

Conquer Electronics Co., LTD.

No.26, Wucyuan 5th Rd., Wugu Dist.,(New Taipei Industrial Park) New Taipei City 24888, Taiwan TEL:+886-2-8990-2189 (代表號) FAX:+886-2-8990-2577

Peitou Factory : No. 15, Lane 120, Lite Road, Peitou, 11259, Taipei, Taiwan. TEL: +886-2-2895-8895 (代表號) FAX:+886-2-2895-8880

E-mail: conqfuse@ms62.hinet.net Official Website: <http://www.conquer.com.tw>



17 信賴性作業規定：

Product Characteristics & Reliability Tests：

Test item	Test Description & Reference
Humidity unload test	MIL-STD-202G， Method 103B， Test Condition A Heat (40±0.5°C) & High Humidity (95±1% RH), 240 hours, ΔR<15%
Thermal shock test	MIL-STD-202G, Method 107g， Test Condition B Temperature setup： 25°C ~ -65°C ~ 25°C ~ 125°C Time setup： -65°C(30min)~25°C(5min)~125°C(30min)~ 25°C(5min) 5 cycles, ΔR<15%
Vibration test	MIL-STD-202G， Method 201A Frequency setup： 10 ~ 55 ~ 10 Hz Time setup： 1 Minutes/cycle (X-Y-Z,120 Cycles) 6hrs, ΔR<15%
Salt spray Test	MIL-STD-202G， Method 101E， Test Condition A Salt spray concentration： 5 ± 1% Test liquid temperature： 35 ± 0.5°C 96hrs, ΔR<15%
Solderability test	Reference IEC 60068-2-20 Temperature setup： 250 ± 3°C, 3 ± 0.3 sec After test terminal electrode wetting area must be greater than 95%
Resistance to Solder Heat Test	Reference IEC 60068-2-20 Temperature setup： 260± 3°C, 10± 1 sec ΔR<15%

Conquer Electronics Co., LTD.

No.26, Wucyuan 5th Rd., Wugu Dist.,(New Taipei Industrial Park) New Taipei City 24888, Taiwan TEL:+886-2-8990-2189 (代表號) FAX:+886-2-8990-2577

Peitou Factory： No. 15, Lane 120, Lite Road, Peitou, 11259, Taipei, Taiwan. TEL: +886-2-2895-8895 (代表號) FAX:+886-2-2895-8880

E-mail: conqfuse@ms62.hinet.net Official Website: <http://www.conquer.com.tw>



18 Temperature Derating curve :

CHAR SHOWING EFFECT OF AMBIENT TEMPERATURE
ON CURRENT-CARRYING CAPACITY

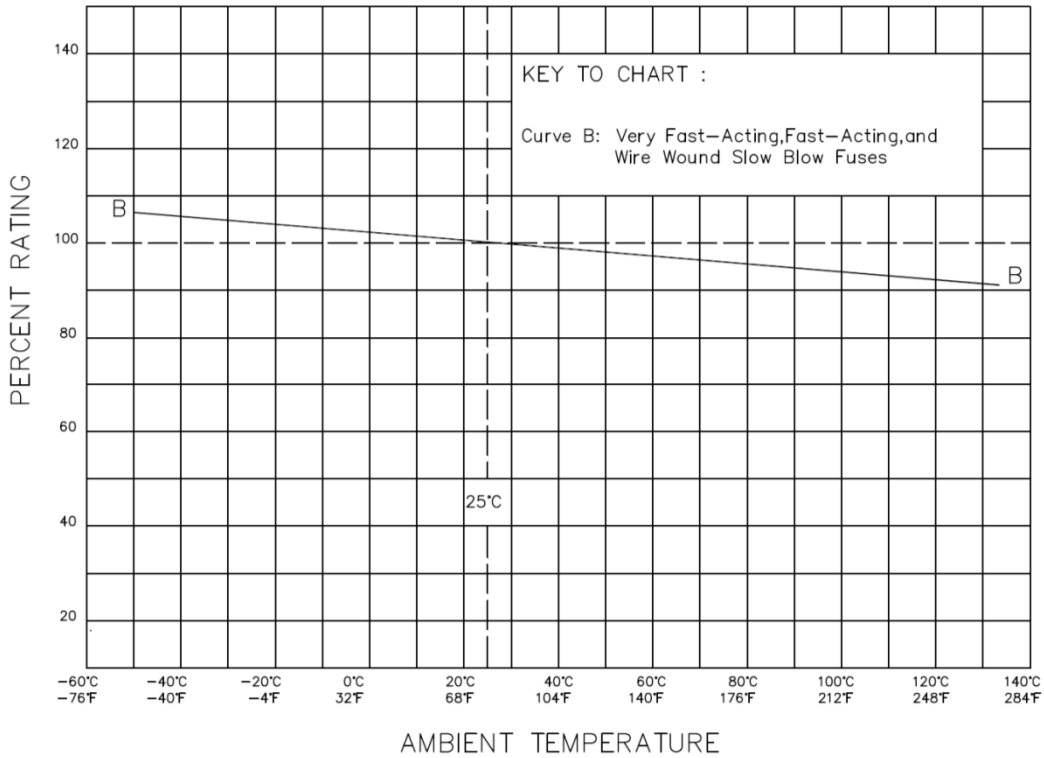

Conquer Electronics Co., LTD.

No.26, Wucyuan 5th Rd., Wugu Dist.,(New Taipei Industrial Park) New Taipei City 24888, Taiwan TEL:+886-2-8990-2189 (代表號) FAX:+886-2-8990-2577

Peitou Factory : No. 15, Lane 120, Lite Road, Peitou, 11259, Taipei, Taiwan. TEL: +886-2-2895-8895 (代表號) FAX:+886-2-2895-8880

E-mail: conqfuse@ms62.hinet.net Official Website: <http://www.conquer.com.tw>